

## PWM Controller With SCP / DTC Function



### General Description

The FP5001 is a single chip pulse-width-modulation controller composed of an open collector transistor output, an error amplifier and duty control comparators (DTC). The FP5001 contains a 1.0V precision voltage reference regulator, under-voltage lockout circuit (UVLO), short circuit protection circuit (SCP). It is applied to offer space and low cost in many applications such as the DC / DC converter and backlight inverter.

Using FP5001, it is easy to complete a power conversion regulator design with few external components. The circuit diagram of the typical application example is shown as below.

### Features

- Wide Operating Voltage Range: 3.6~40V
- Reference Voltage Precision: 2%
- Oscillator Frequency: 500KHz Max.
- Output sink current up to 100mA
- Low Quiescent Supply Current
- Variable Dead-time Control (DTC)
- UVLO Protection Function
- SCP Protection Function
- Package: SOP-8L

### Applications

- Graphic Card
- Telecom and Datacom Applications
- High Power DC-DC Regulators

### Typical Application Circuit

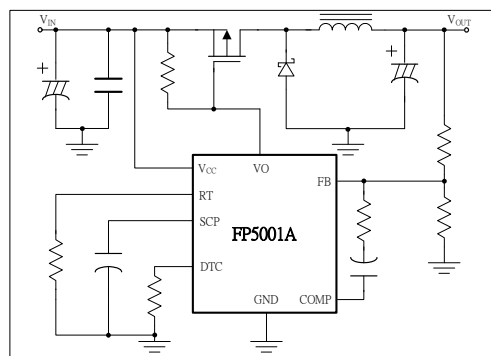

This datasheet contains new product information. Feeling Technology reserves the rights to modify the product specification without notice. No liability is assumed as a result of the use of this product. No rights under any patent accompany the sales of the product.

## Function Block Diagram

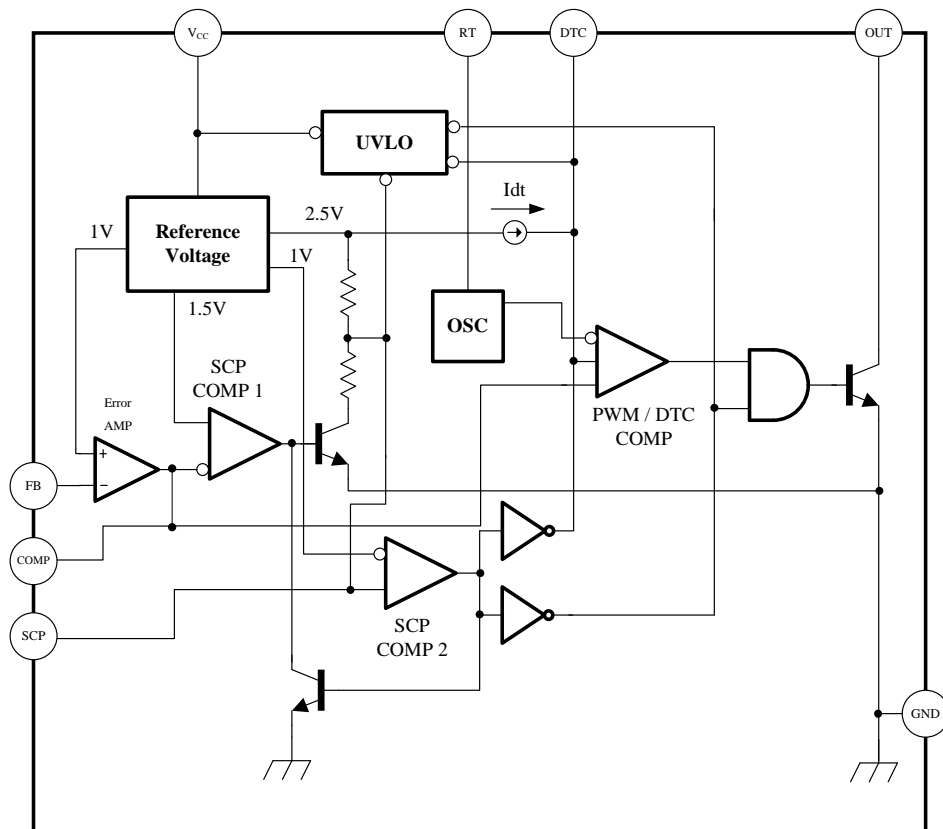

## Pin Descriptions

### SOP-8L

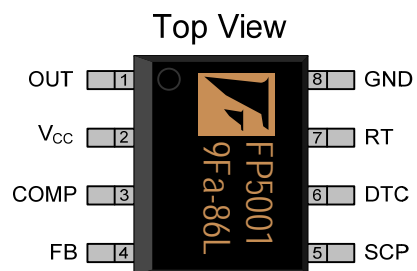

Name	No.	I / O	Description
OUT	1	O	Open Collector Transistor Output
V <sub>cc</sub>	2	P	IC Power Supply
COMP	3	O	Error Amplifier Output
FB	4	I	Error Amplifier Inverting Input
SCP	5	I	Short Circuit Protection Input
DTC	6	I	Duty Control Input
RT	7	I	Oscillator Frequency Control Input
GND	8	P	IC Ground

This datasheet contains new product information. Feeling Technology reserves the rights to modify the product specification without notice. No liability is assumed as a result of the use of this product. No rights under any patent accompany the sales of the product.

## Marking Information

### SOP-8L

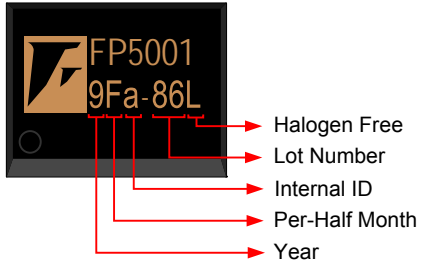

**Halogen Free:** Halogen free product indicator

**Lot Number:** Wafer lot number's last two digits

For Example: 132386TB → 86

**Internal ID:** Internal Identification Code n

**Per-Half Month:** Production period indicated in half month time unit

For Example: January → A (Front Half Month), B (Last Half Month)

February → C (Front Half Month), D (Last Half Month)

**Year:** Production year's last digit

## Ordering Information

Part Number	Operating Temperature	Package	MOQ	Description
FP5001DR-LF	-20°C ~ +85°C	SOP-8L	2500EA	Tape & Reel

## Absolute Maximum Ratings

Parameter	Symbol	Conditions	Min.	Typ.	Max.	Unit
Power Supply Voltage	$V_{CC}$				40	V
Differential Input Voltage	$V_{ID}$				20	V
Collector Output Voltage	$V_o$				40	V
Collector Output Current	$I_o$				150	mA
Maximum Junction Temperature	$T_J$				150	°C
Junction to Ambient Thermal Resistance		SOP-8L Package			+175	°C / W
Power Dissipation (SOP-8L package)		$T_A=25^\circ\text{C}$			650	mW
		$T_A=70^\circ\text{C}$			550	mW
Storage Temperature Range			-65		+150	°C
Lead Temperature (Soldering, 10 sec)					+260	°C

## IR Re-flow Soldering Curve

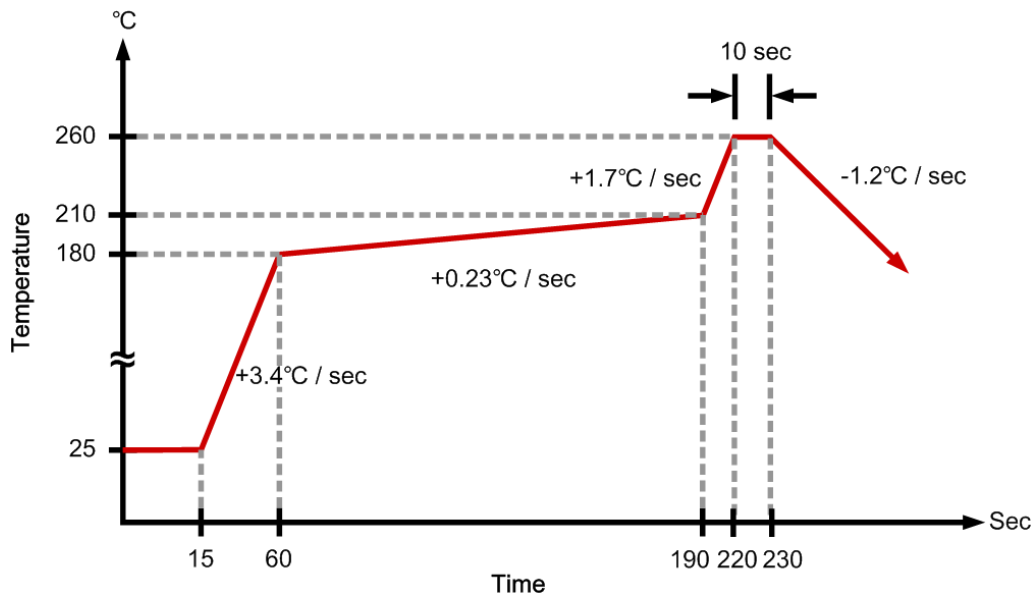

This datasheet contains new product information. Feeling Technology reserves the rights to modify the product specification without notice. No liability is assumed as a result of the use of this product. No rights under any patent accompany the sales of the product.

## Recommended Operating Conditions

Parameter	Symbol	Conditions	Min.	Typ.	Max.	Unit
Supply Voltage	$V_{CC}$		3.6		40	V
Operating Temperature			-20		+85	°C
Operating Junction Temperature			-65		+150	°C

## DC Electrical Characteristics ( $V_{CC}=6V$ , $T_A=25^\circ C$ , $f_{OSC}=70KHz$ unless otherwise specified)

Parameter	Symbol	Conditions	Min.	Typ.	Max.	Unit
<b>Reference</b>						
Output Voltage	$V_{REF}$	COMP Connected to FB	0.98	1	1.02	V
Input Regulation	$\Delta V_{REF}$	$V_{CC} = 3.6 V$ to $40 V$		2	12.5	mV
Output Voltage Change with Temperature	$\Delta V_{REF} / V_{REF}$	$T_A = -20^\circ C$ to $25^\circ C$	-10	-1	15	mV / V
		$T_A = 25^\circ C$ to $85^\circ C$	-10	-2	10	mV / V
<b>Under Voltage Lockout</b>						
Upper Threshold Voltage	$V_{upper}$			3		V
Lower Threshold Voltage	$V_{low}$			2.8		V
Hysteresis	$V_{hys}$		100	200		mV
Reset Threshold Voltage	$V_{reset}$		2.1	2.55		V
<b>Short-Circuit Protection</b>						
SCP Threshold Voltage	$V_{TH}$		0.95	1.00	1.05	V
SCP Voltage, Latched	$V_{LATCH}$	No Pullup		2.4		V
SCP Voltage, UVLO Operation	$V_{OPR}$		140	185	230	mV
SCP Voltage, UVLO Standby	$V_{STANDBY}$	No Pullup		60	120	mV
Input Source Current	$I_{SOURCE}$	$T_A = 25^\circ C$	-10	-15	-20	$\mu A$
SCP Comparator 1 Threshold Voltage	$V_{COMP(TH)}$			1.5		V
<b>Oscillator</b>						
Frequency	$f$	$R_T = 100K$		70		KHz
Standard Deviation of Frequency	$\Delta f$			15		KHz
Frequency Change with Voltage	$\Delta f / \Delta V$	$V_{CC} = 3.6V$ to $40V$		1		KHz
Frequency Change with Temperature	$\Delta f / \Delta T$	$T_A = -20^\circ C$ to $25^\circ C$	-4	-0.4	4	KHz
		$T_A = 25^\circ C$ to $85^\circ C$	-4	-0.2	4	KHz
Voltage at RT	$V_{RT}$			1		V

This datasheet contains new product information. Feeling Technology reserves the rights to modify the product specification without notice. No liability is assumed as a result of the use of this product. No rights under any patent accompany the sales of the product.

**DC Electrical Characteristics (Cont.)**

Parameter	Symbol	Conditions	Min.	Typ.	Max.	Unit
<b>Duty Control</b>						
Output (Source) Current	$I_{SOURCE}$	$V_{(DT)} = 1.5V$	$0.9 \times I_{RT}^{\ddagger}$		$1.2 \times I_{RT}$	$\mu A$
Input Threshold Voltage	$V_{TH}$	Duty Cycle = 0%	0.5	0.7		V
		Duty Cycle = 100%		1.3	1.5	V
<b>Error Amplifier</b>						
Input Voltage	$V_{IN}$	$V_{CC} = 3.6V$ to 40V	0		1.5	V
Input Bias Current	$V_{BIAS}$			-160	-500	nA
Output Voltage Swing Positive	$V_{POS}$		1.5	2.3		V
Output Voltage Swing Negative	$V_{NEG}$			0.3	0.4	V
Open-loop Voltage Amplification	$A_{VO}$			80		dB
Unity-Gain Bandwidth	$BW_U$			1.5		MHz
Output ( Sink ) Current	$I_{SINK}$	$V_{I (FB)} = 1.2V$ , COMP = 1V	600	1100		$\mu A$
Output ( Source ) Current	$I_{SOURCE}$	$V_{I (FB)} = 0.8V$ , COMP = 1V	-45	-70		$\mu A$
<b>Output</b>						
Output Saturation Voltage	$V_{SAT}$	$I_O = 10mA$		0.8	1.2	V
Off-state Current	$I_{OFF}$	$V_O = 40V$ , $V_{CC} = 0$			10	$\mu A$
		$V_O = 40V$			10	$\mu A$
Short-circuit Output Current	$I_{SC}$	$V_O = 6V$		40		mA
<b>Total Device</b>						
Standby Supply Current Off State	$I_{STANDBY}$			1	1.5	mA
Average Supply Current	$I_{AVE}$	$R_T = 100k$		1.2	1.5	mA

This datasheet contains new product information. Feeling Technology reserves the rights to modify the product specification without notice. No liability is assumed as a result of the use of this product. No rights under any patent accompany the sales of the product.

## Function Description

### Voltage Reference

A 2.5-V regulator operating from  $V_{CC}$  is used to power the internal circuitry of the FP5001. A resistive divider provides 1V reference for the error amplifier and the SCP circuit.

### Error Amplifier

The error amplifier compares a sample of the DC-DC converter's output voltage to the 1V reference and generates an error signal for the PWM comparator. The DC-DC converter's output voltage can be set by following expression:

$$V_o = (1 + R1 / R2) \times (1 V)$$

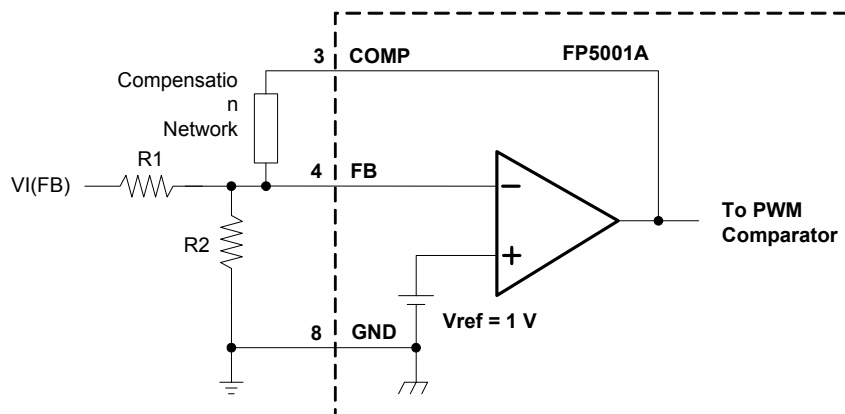

Figure 1. Error-Amplifier Gain Setting

The error amplifier's output is brought out as COMP for use in compensating the DC-DC converter's control loop for stability. Because the amplifier can only source 45  $\mu$ A, the total DC load resistance should be 100 k $\Omega$  or larger.

### Oscillator / PWM

The oscillator frequency ( $f_{osc}$ ) can be set from 20 kHz to 500 kHz by connecting a resistor between RT and GND. Acceptable resistor values range from 15 k $\Omega$  to 250 k $\Omega$ . The oscillator frequency can be determined by using the graph shown in Figure 5.

The oscillator output is a triangular wave with a minimum value of approximately 0.7 V and a maximum value of approximately 1.3 V. The PWM comparator compares the error amplifier's output voltage and the DTC input voltage to the triangular wave. It turns the output transistor off whenever the triangular wave is greater than the lesser of the two inputs.

This datasheet contains new product information. Feeling Technology reserves the rights to modify the product specification without notice. No liability is assumed as a result of the use of this product. No rights under any patent accompany the sales of the product.

### Duty Control (DTC)

DTC provides a means of limiting the output-switch duty cycle to a value less than 100%, which is critical for boost and flyback converters. A current source generates a reference current ( $I_{DT}$ ) at DTC that is nominally equal to the current at the oscillator timing terminal,  $R_T$ . Connecting a resistor between DTC and GND generates a maximum duty reference voltage ( $V_{DT}$ ), which the PWM/DTC comparator compares to the oscillator triangle wave as described in the previous section. Nominally, the maximum duty cycle is 0% when  $V_{DT}$  is smaller than 0.7 V and 100% when  $V_{DT}$  is 1.3 V or greater. Because the triangle wave amplitude is a function of frequency and the source impedance of  $R_T$  is relatively high (1250  $\Omega$ ), choosing  $R_{DT}$  for a specific maximum duty cycle,  $D$ , is accomplished using the following equation. The voltage limits for the frequency in question can be found in Figure 11 ( $V_{osc,max}$  and  $V_{osc,min}$  are the maximum and minimum oscillator levels):

$$R_{DT} = (R_T + 1250) [D (V_{osc,max} - V_{osc,min}) + V_{osc,min}]$$

Where

$R_{DT}$  and  $R_T$  are in ohms,  $D$  in decimal

Soft start can be implemented by paralleling the DTC resistor with a capacitor ( $C_{DT}$ ) as shown in Figure 2. During soft start, the voltage at DTC is derived by the following equation:

$$V_{DT} \approx I_{DT} R_{DT} \left( 1 - e^{-t/R_{DT} C_{DT}} \right)$$

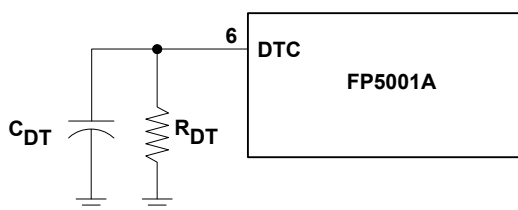

**Figure 2. Soft-Start Circuit**

If the DC-DC converter must be in regulation within a specified period of time, the time constant,  $R_{DT} C_{DT}$ , should be  $t_0/3$  to  $t_0/5$ . The FP5001 remains off when  $V_{DT} < 0.7$  V, the minimum OSC ramp value.  $C_{DT}$  is discharged every time UVLO or SCP becomes active.



## Under Voltage Lockout (UVLO) Protection

The under voltage lockout circuit turns the output transistor off and resets the SCP latch whenever the supply voltage drops too low (approximately 3 V at 25°C) for proper operation.

A hysteresis voltage of 200 mV eliminates false triggering on noise and chattering.

## Short-circuit Protection (SCP)

The FP5001 includes short-circuit protection (see Figure 3), which turns the power switch off to prevent damage when the converter output is shorted. When activated, the SCP prevents the switch from being turned on until the internal latching circuit is reset. The circuit is reset by reducing the input voltage until UVLO becomes active or until the SCP terminal is pulled to ground externally.

When a short circuit occurs, the error-amplifier output at COMP rises to increase the power-switch duty cycle in an attempt to maintain the output voltage. SCP comparator 1 starts an RC timing circuit when COMP exceeds 1.5V. If the short is removed and the error-amplifier output drops below 1.5V before time out, normal converter operation continues. If the fault is still present at the end of the time-out period, the timer sets the latching circuit and turns off the FP5001 output transistor.

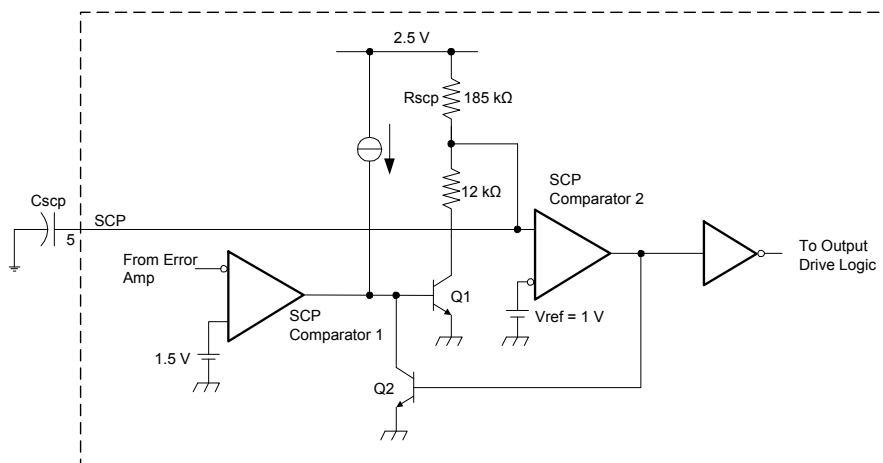

Figure 3. SCP Circuit

The timer operates by charging an external capacitor (CSCP), connected between the SCP terminal and ground, towards 2.5V through a 185-kΩ resistor (RSCP). The circuit begins charging from an initial voltage of approximately 185 mV and times out when the capacitor voltage reaches 1V. The output of SCP comparator 2 then goes high, turns on Q2, and latches the timer circuit. The expression for setting the SCP time period is derived from the following equation:

$$V_{SCP} = (2.5 - 0.185)(1 - e^{-t/\tau}) + 0.185$$

Where

$$\tau = R_{SCP}C_{SCP}$$

This datasheet contains new product information. Feeling Technology reserves the rights to modify the product specification without notice. No liability is assumed as a result of the use of this product. No rights under any patent accompany the sales of the product.

The end of the time-out period,  $t_{SCP}$ , occurs when  $V_{SCP} = 1\text{ V}$ . Solving for  $C_{SCP}$  yields:

$$C_{SCP} = 12.46 \times t_{SCP} \quad \text{Where } t \text{ is in seconds, } C \text{ in } \mu\text{F}.$$

$t_{SCP}$  must be much longer (generally 10 to 15 times) than the converter start-up period or the converter will not start.

### Output Transistor

The output of the FP5001 is an open-collector transistor with a maximum collector current rating of 100mA and a voltage rating of 40V. The output is turned on under the following conditions: the oscillator triangle wave is lower than both the DTC voltage and the error-amplifier output voltage, the UVLO circuit is inactive, and the short-circuit protection circuit is inactive.

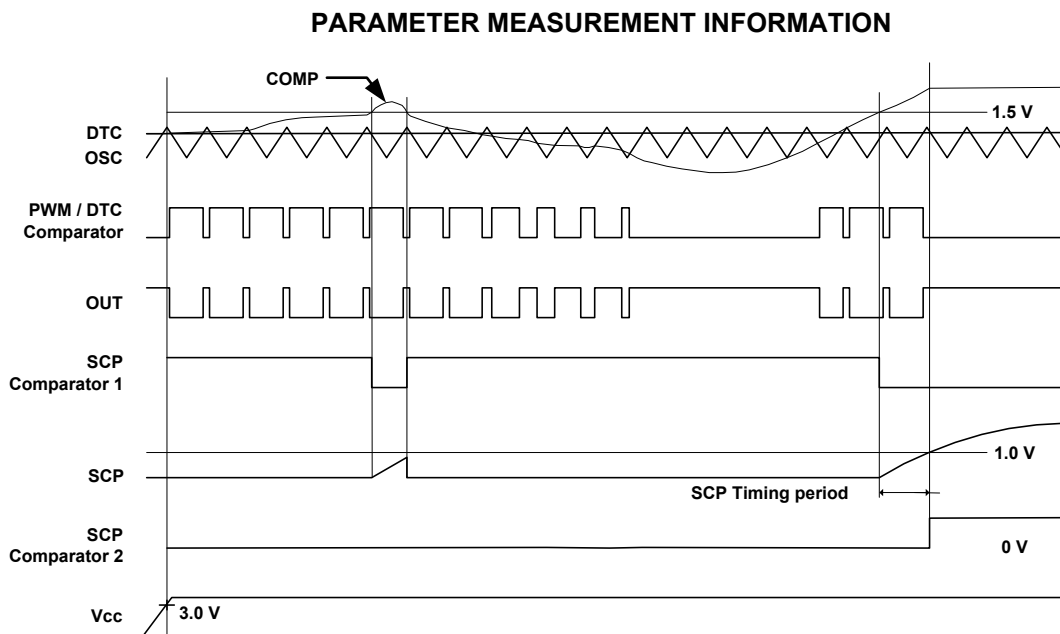
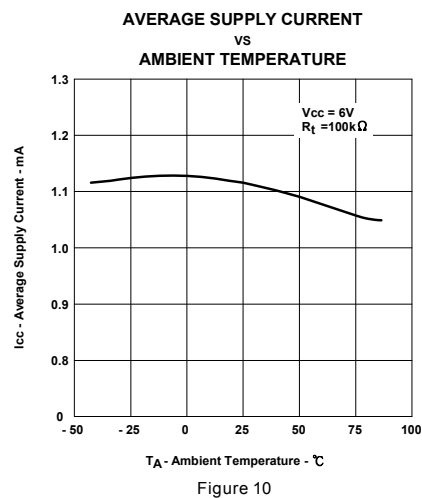
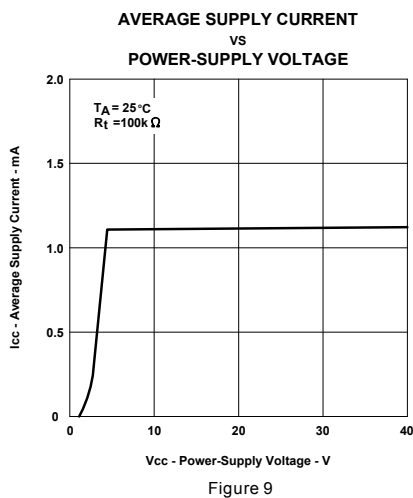
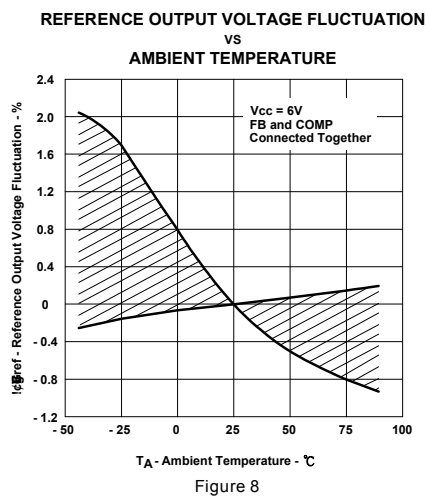
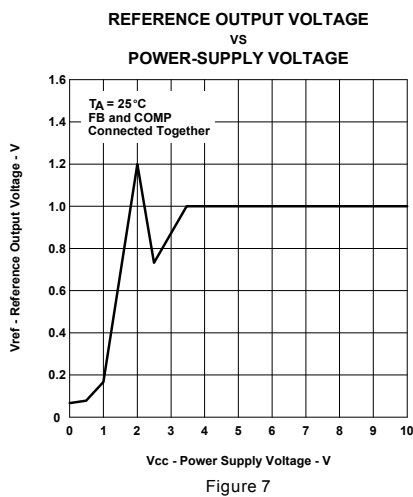
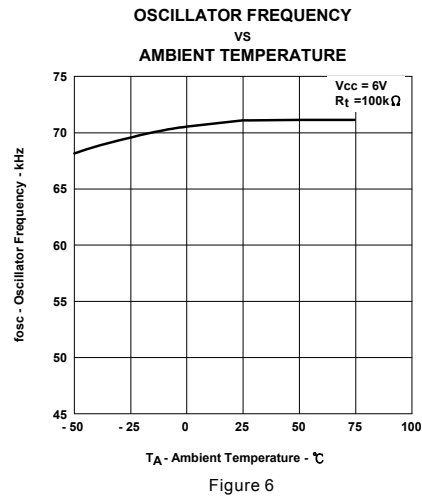
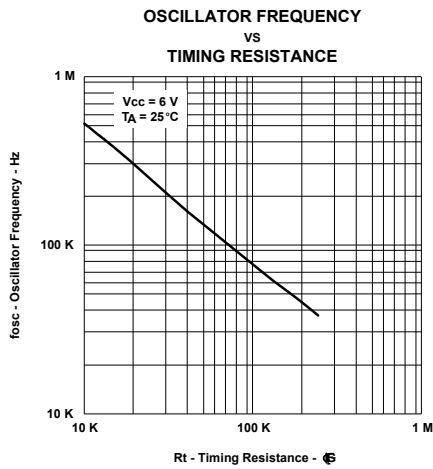

Figure 4. PWM Timing Diagram

This datasheet contains new product information. Feeling Technology reserves the rights to modify the product specification without notice. No liability is assumed as a result of the use of this product. No rights under any patent accompany the sales of the product.

## Typical Operating Characteristics



This datasheet contains new product information. Feeling Technology reserves the rights to modify the product specification without notice. No liability is assumed as a result of the use of this product. No rights under any patent accompany the sales of the product.

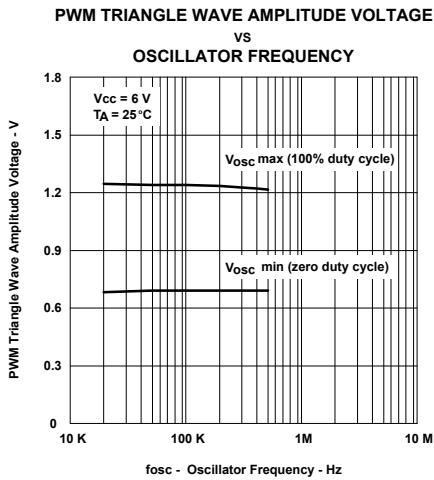

Figure 11

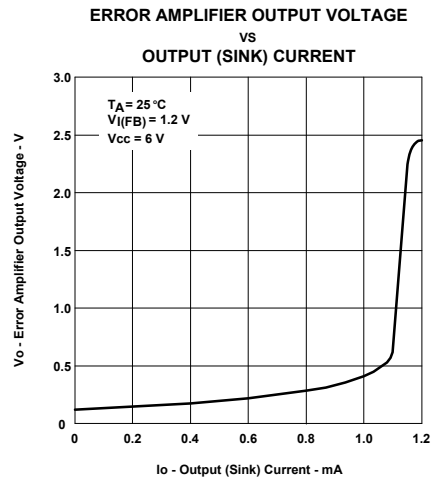

Figure 12

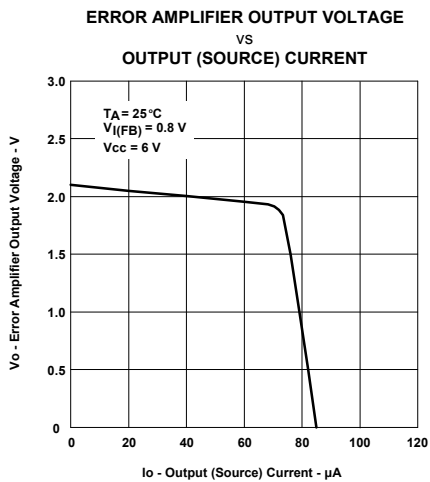

Figure 13

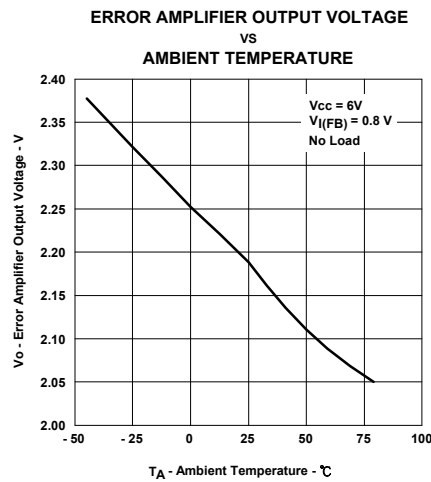

Figure 14

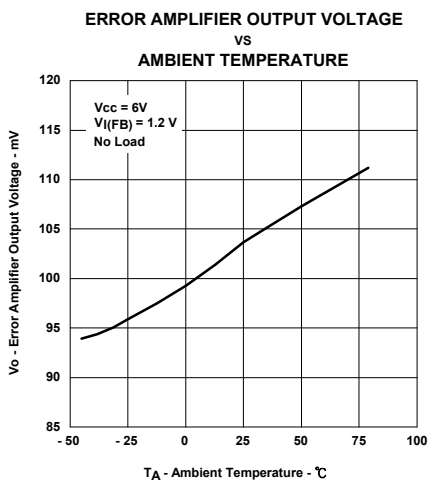

Figure 15

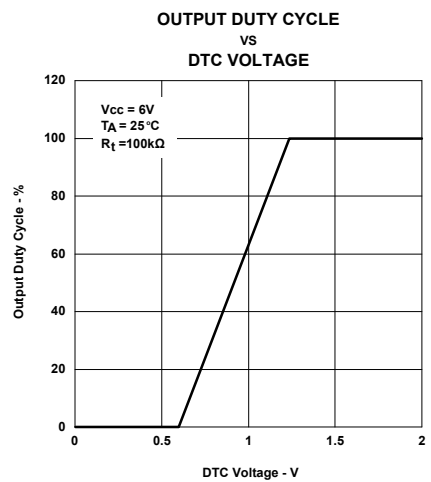

Figure 16

This datasheet contains new product information. Feeling Technology reserves the rights to modify the product specification without notice. No liability is assumed as a result of the use of this product. No rights under any patent accompany the sales of the product.

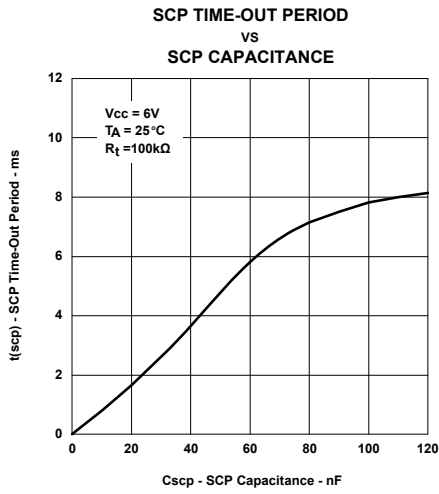

Figure 17

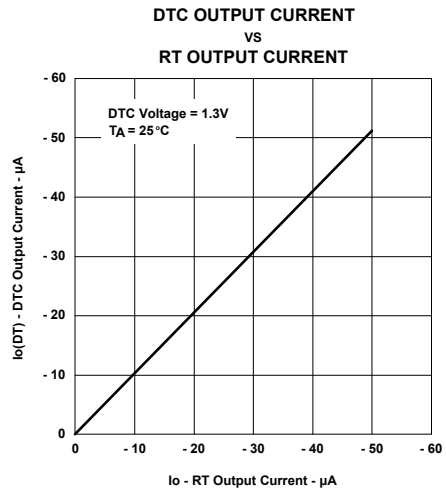

Figure 18

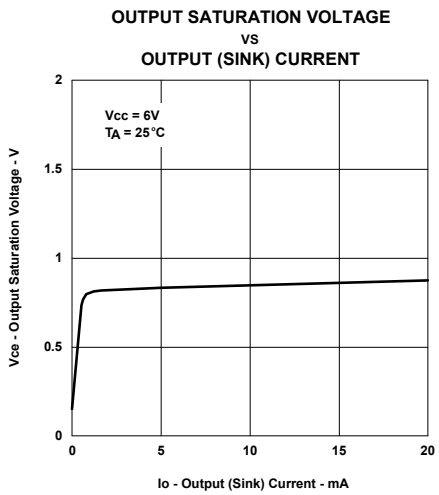
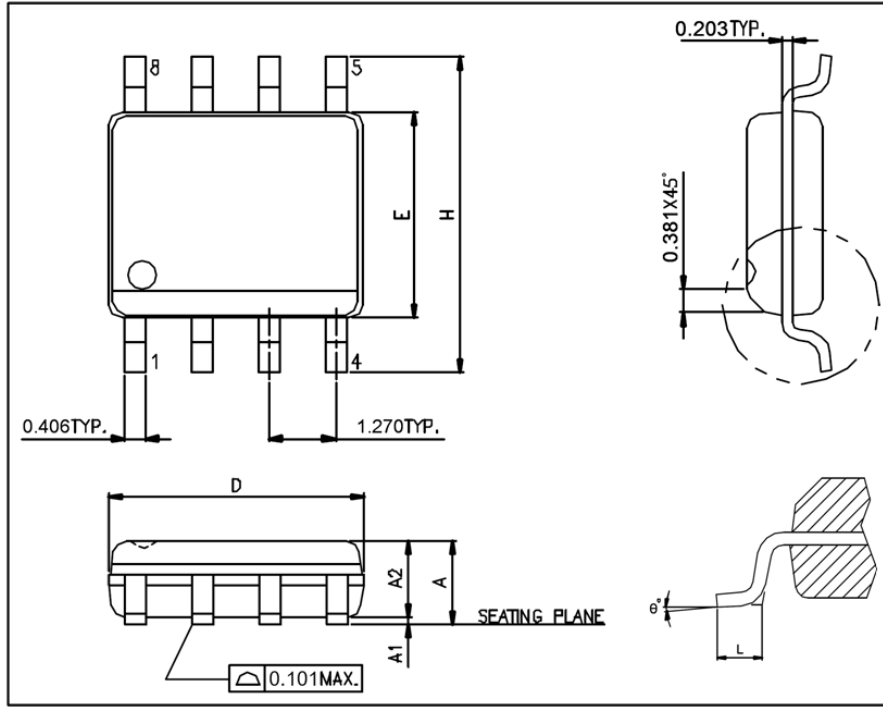

Figure 19

This datasheet contains new product information. Feeling Technology reserves the rights to modify the product specification without notice. No liability is assumed as a result of the use of this product. No rights under any patent accompany the sales of the product.

## Package Outline

### SOP-8L



UNIT: mm

Symbols	Min. (mm)	Max. (mm)
A	1.346	1.752
A1	0.101	0.254
A2		1.498
D	4.800	4.978
E	3.810	3.987
H	5.791	6.197
L	0.406	1.270
θ°	0°	8°

#### Note:

1. Package dimensions are in compliance with JEDEC outline: MS-012 AA.
2. Dimension "D" does not include molding flash, protrusions or gate burrs.
3. Dimension "E" does not include inter-lead flash or protrusions.

This datasheet contains new product information. Feeling Technology reserves the rights to modify the product specification without notice. No liability is assumed as a result of the use of this product. No rights under any patent accompany the sales of the product.